

A-Anchor System

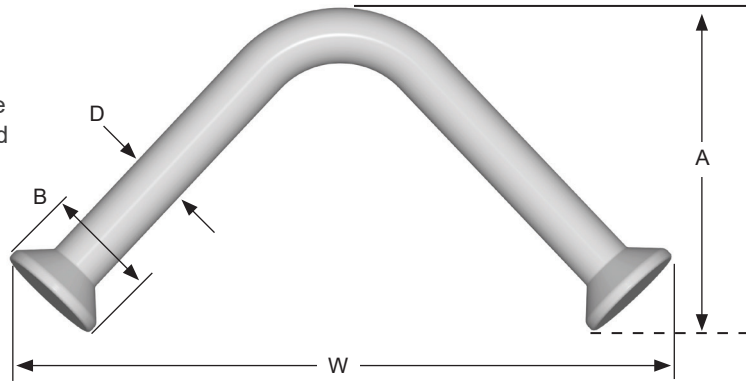

14 and 18 MM A-Anchors

CONAC A-Anchors are available in standard finish galvanized and self color.



ITEM CODE	SLAB MIN. THICKNESS	SWL TENSION	SWL AT 90° SHEAR	END DISTANCE
4CA12	4"	2600	4000	9"
4CA14	4"	3500	5400	9"
5CA14	5"	5500	8500	10"
5CA18	5"	6000	9300	10"
6CA14	6"	6500	10100	12-1/2"
6CA18	6"	7500	11600	12-1/2"
8CA18	8"	13000	20000	15-1/2"

Note: Safe working loads based on approximate 4:1 safety factor with a minimum concrete strength of 4,000 psi. For use as pulling iron load may be increased by up to 33% with a Safety Factor of 3:1.

ITEM CODE	DEPTH (A)	ANCHOR WIDTH (W)	BODY DIA. (D)	BASE DIA. (B)	PANEL DEPTH
4CA12	3-1/4"	5-1/8"	1/2"	1-3/16"	4"
4CA14	3-1/8"	6-5/16"	9/16"	1-3/16"	4"
5CA14	3-3/4"	8-1/4"	9/16"	1-3/16"	5"
5CA18	3-3/4"	8-11/16"	11/16"	2"	5"
6CA14	4-3/4"	10-9/16"	9/16"	1-9/16"	6"
6CA18	4-3/4"	9-1/16"	11/16"	2"	6"
8CA18	6-3/4"	12-1/4"	11/16"	2"	8"

CONAC A-Anchors are available in Stainless Steel 316 upon request.

A-Anchor Rubber Recess Formers

A-Anchor Rubber Recess Formers are manufactured in 90° angles. The recess former sets the top of the anchor 3/4" below the surface of the concrete.

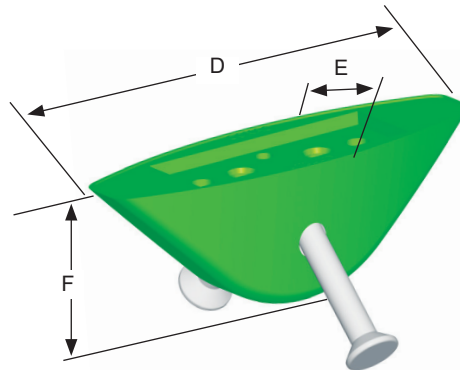

ITEM CODE	D	E	F	COLOR
CRRF9014	9"	3"	3-1/4"	Red
CRRF9018	9"	3"	3-1/4"	Black
CRRF9014-4	9"	3"	4"	Yellow
CRRF9018-4	9"	3"	4"	Green
CRRF1118	11"	3-1/8"	3-1/2"	Black

A-Anchor Plastic Recess Formers

A-Anchor single use plastic recess formers attach to mesh or rebar cages. Patent # 8,024,896

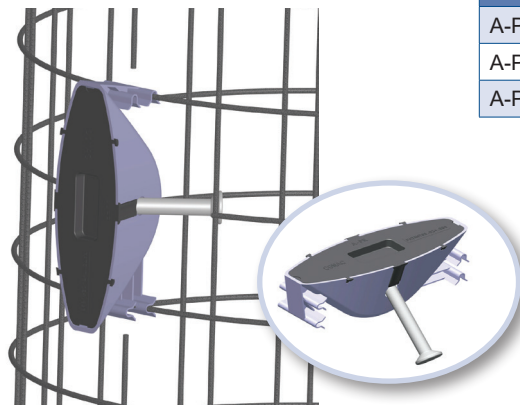

ITEM CODE	D	E	F	QTY/BOX
A-PRF-1	9"	3"	3-1/4"	110 PCS
A-PRF-1-18	9"	3"	3-1/4"	110 PCS
A-PRF-1-18-1/2	11"	4-1/8"	4"	60 PCS

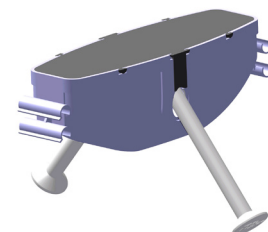

A-PRF-1-18-1/2 Designed for Box Culvert Lifting

A-Anchor System

.444" And .671" A-Anchors

CONAC A-Anchors are available in standard finish galvanized and self color.

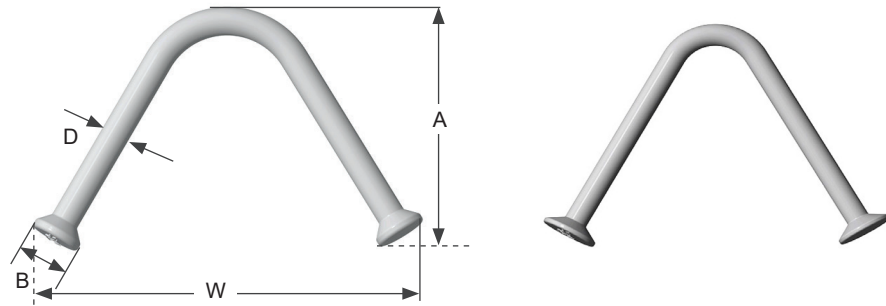

ITEM CODE	SLAB MIN. THICKNESS	SWL TENSION	SWL AT 90° SHEAR	END DISTANCE
4CA44	4"	3200	5800	9"
5CA44	5"	3860	7710	11"
6CA44	6"	4460	9460	15"
5CA67	5"	4560	8430	11"
6CA67	6"	7320	15780	15"
8CA67	8"	10830	18850	20"

ITEM CODE	DEPTH (A)	ANCHOR WIDTH (W)	BODY DIA. (D)	BASE DIA. (B)	PANEL DEPTH
4CA44	3-1/8"	5-1/4"	0.444"	1-1/8"	4"
5CA44	3-3/4"	6"	0.444"	1-1/8"	5"
6CA44	4-3/4"	7-3/8"	0.444"	1-1/8"	6"
5CA67	3-3/4"	6-7/16"	0.671"	1-5/8"	5"
6CA67	4-3/4"	7-3/8"	0.671"	1-5/8"	6"
8CA67	6-3/4"	9-3/4"	0.671"	1-5/8"	8"

Note: Safe working loads based on approximate 4:1 safety factor with a minimum concrete strength of 4,000 psi. For use as pulling iron load may be increased by up to 33% with a Safety Factor of 3:1.

A-Anchor Rubber Recess Formers

A Anchor Rubber Recess Formers are manufactured in 90° angles. The recess former sets the top of the anchor 3/4" below the surface of the concrete.

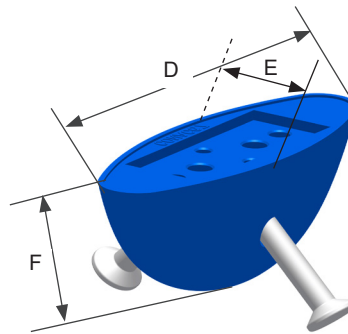

ITEM CODE	D	E	F	COLOR
CRRF9044	8"	3"	3.5"	Blue
CRRF9067	8"	3"	3.5"	Green

A-Anchor Plastic Recess Formers

A-Anchor single use plastic recess formers attach to mesh or rebar cages. Patent # 8,024,896

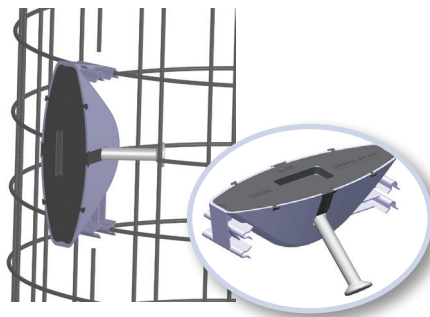

ITEM CODE	D	E	F	QTY/BOX
A-PRF-44	9"	3"	3.25"	110 PCS
A-PRF-1-18	9"	3"	3.25"	110 PCS

A-Anchor with Clip

Welded clips allow mounting to wire mesh cage. Available in various clip sizes and configurations.

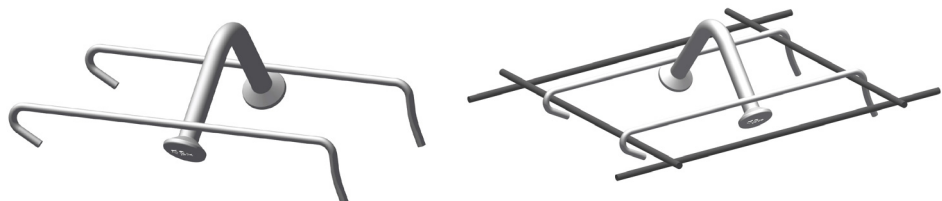

A-Anchor System



A-Anchor Magnetic Setting Plate

The A-Anchor Magnetic Recess Plate allows attachment of the Rubber Recess Former to any steel form, eliminating bolting or welding. Threaded holes in magnet (3/8"-16 NC) allow easy release of magnet from form.

ITEM CODE	DESCRIPTION
A-Magnetic Plate	For 14 and 18 mm Anchors
A-Magnetic Plate 44	For .44" and .67" Anchors

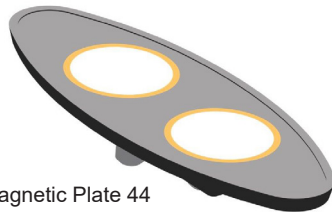

A-Magnetic Plate 44

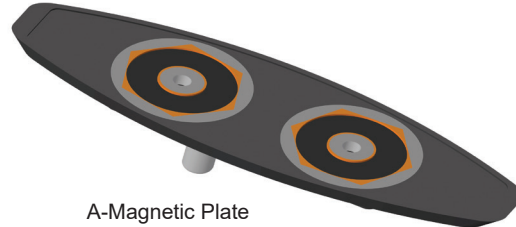

A-Magnetic Plate

A-Anchor Setting Plate

The A-Anchor Setting Plate is used in various applications to install A-Anchors in a form using rubber recess former.

ITEM CODE	DESCRIPTION
Setting Plate	For 14 and 18 mm Anchors
Setting Plate 44	For .44" and .67" Anchors

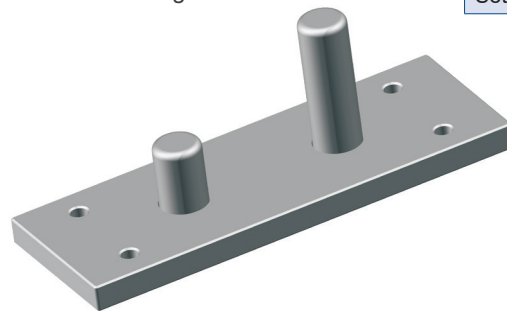

A-Anchor Setting Rod

The Setting Rod is used to set the rubber recess former in place by way of a pre-drilled hole in the form.

ITEM CODE	THREAD SIZE	DESCRIPTION
A-Setting Rod	3/8" NC Thread	For 14 and 18 mm Anchors
FWNC 1/2"	1/2" Coil Thread	For .44" and .67" Anchors

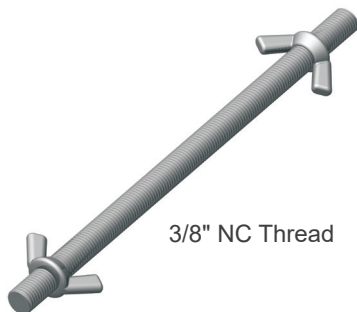

3/8" NC Thread

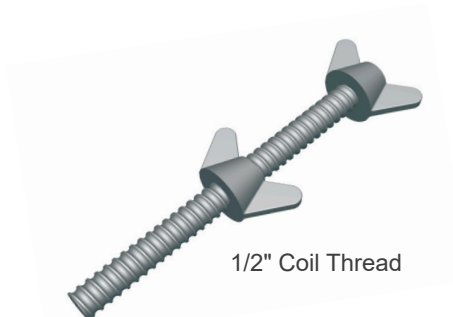

1/2" Coil Thread